

TYPICAL COLUMN TO BEAM CONNECTION DETAILS

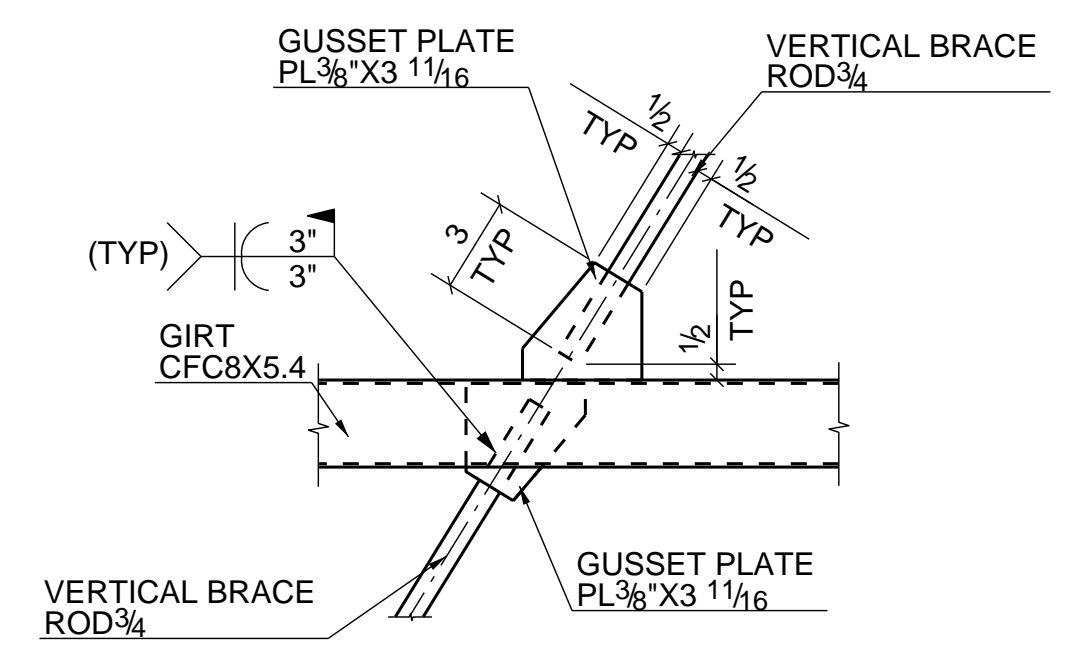

TYPICAL BRACE CONNECTION DETAIL

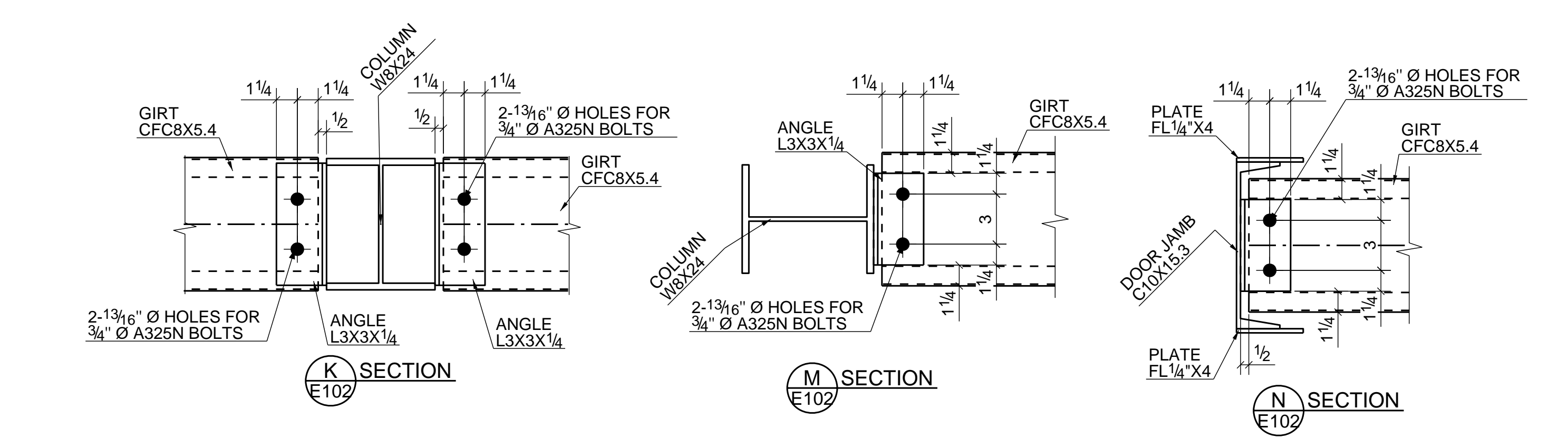

TYPICAL GIRT CONNECTION DETAILS

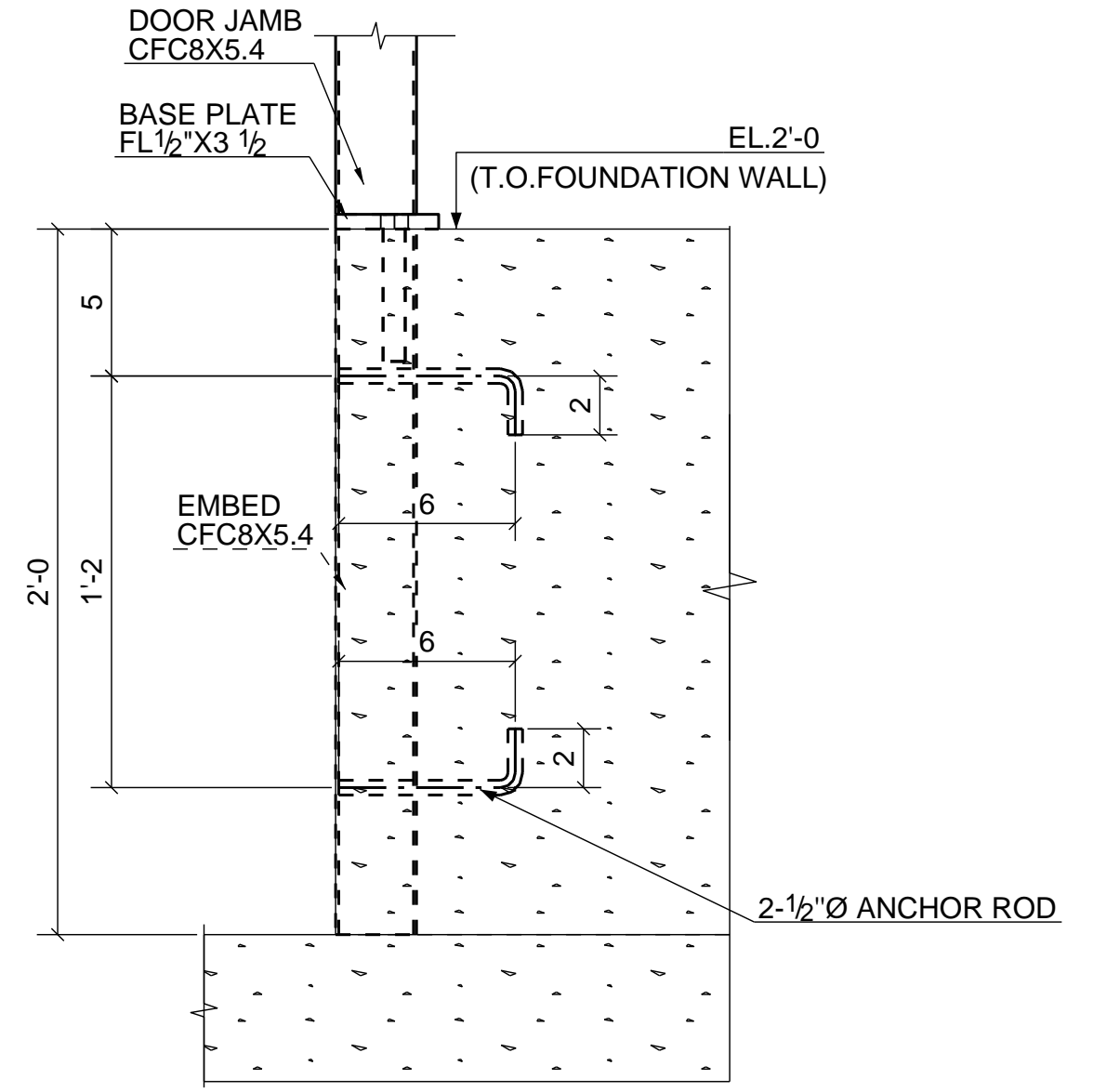

TYPICAL EMBED DETAIL

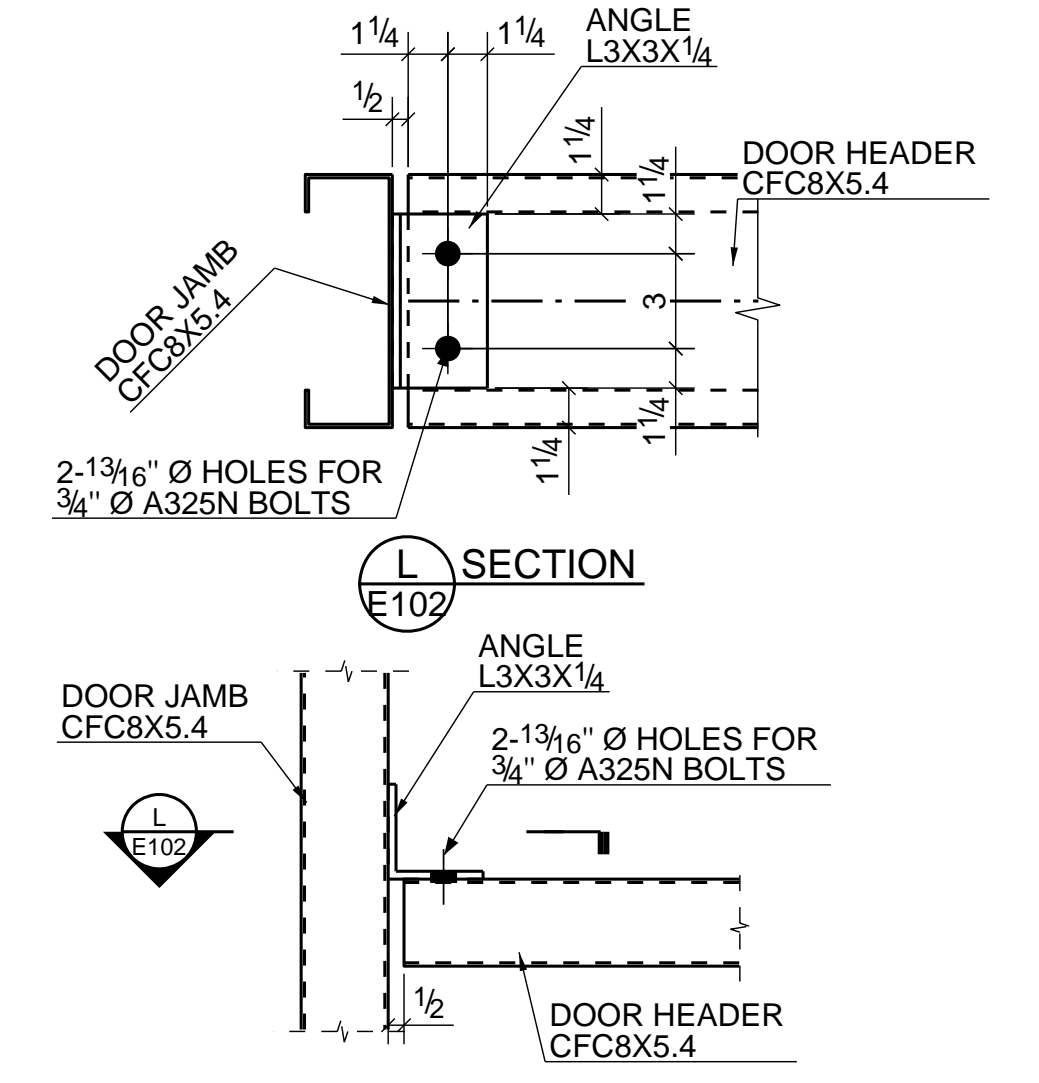

TYPICAL DOOR HEADER CONNECTION DETAIL

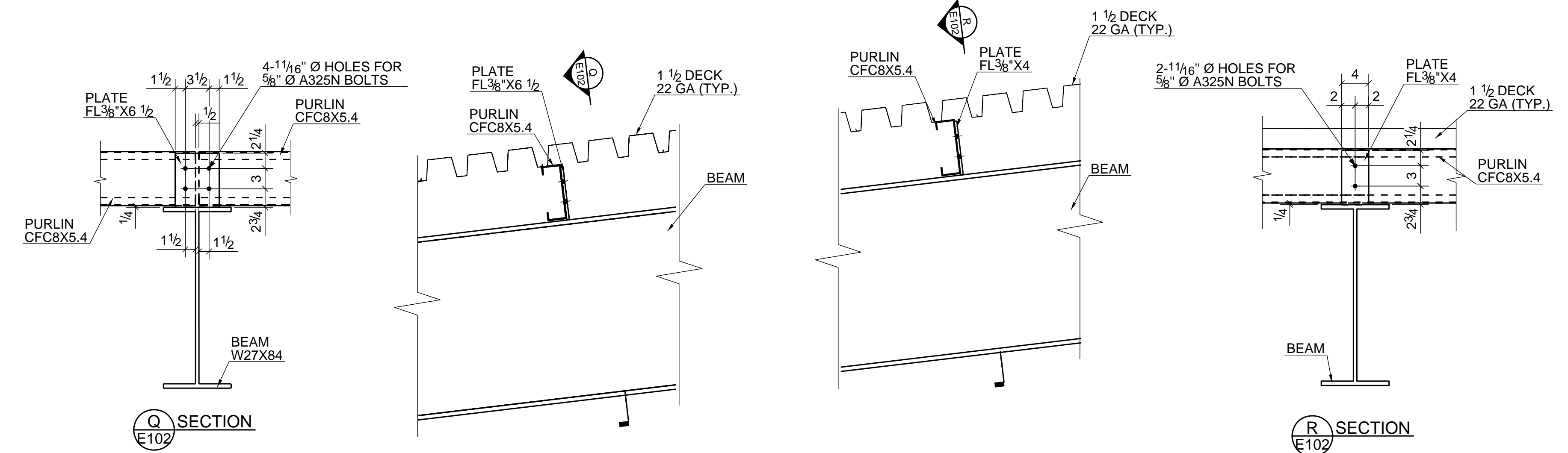

TYPICAL PURLIN CONNECTION DETAILS