

FOR STEEL ERECTION ONLY

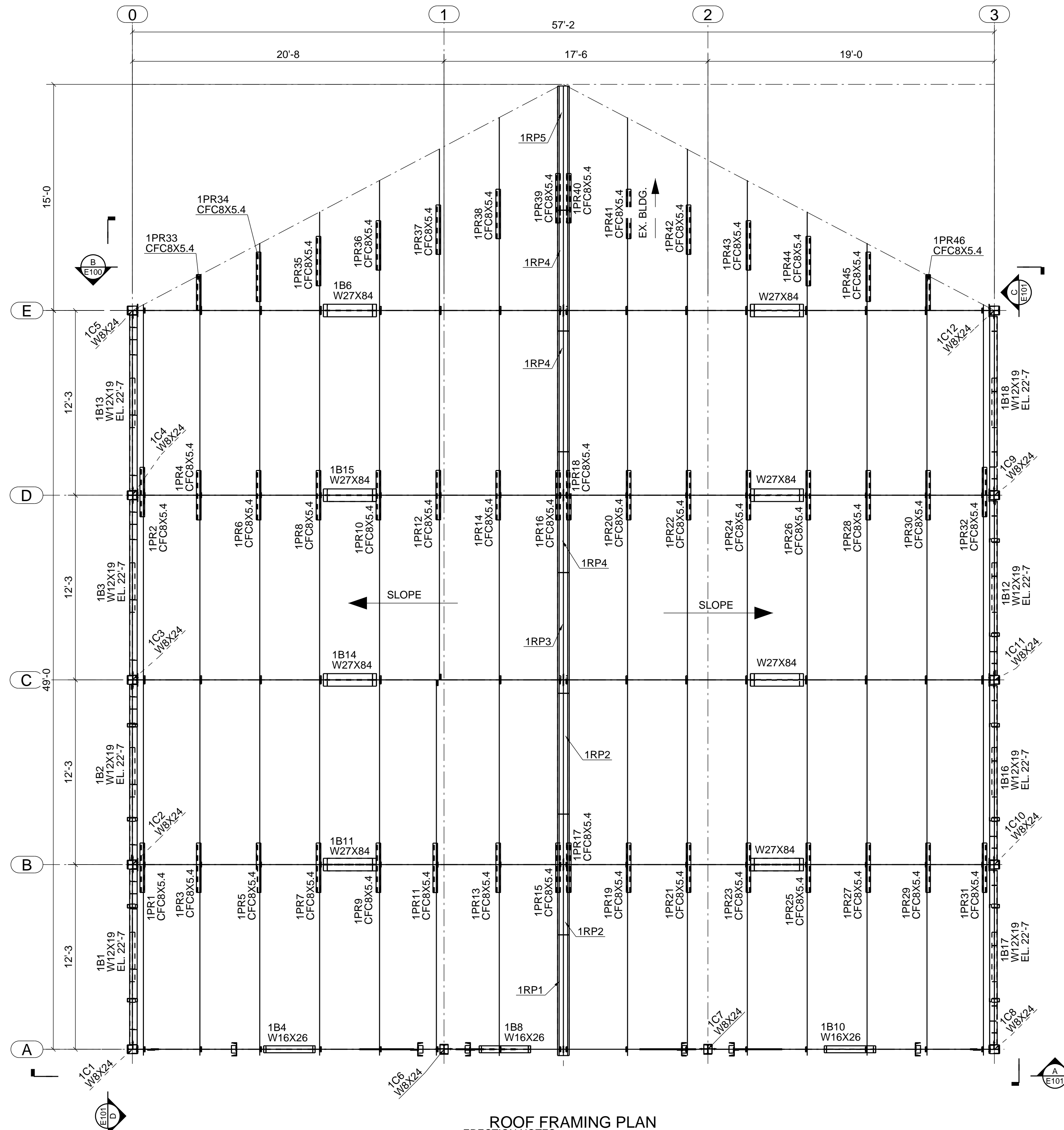

ROOF FRAMING PLAN

- ERECTION NOTES:
 1 - TOP OF STEEL EL = SEE PLAN.
 2 - ALL W-SHAPES ARE 50W AND CHANNELS, ANGLES, PLATES & BARS ARE 44W.
 3 - ALL BOLTS TO BE H.S. BOLTS 3/4" Ø A325N U.N.O.

REFER E102 FOR TYPICAL CONNECTION DETAILS

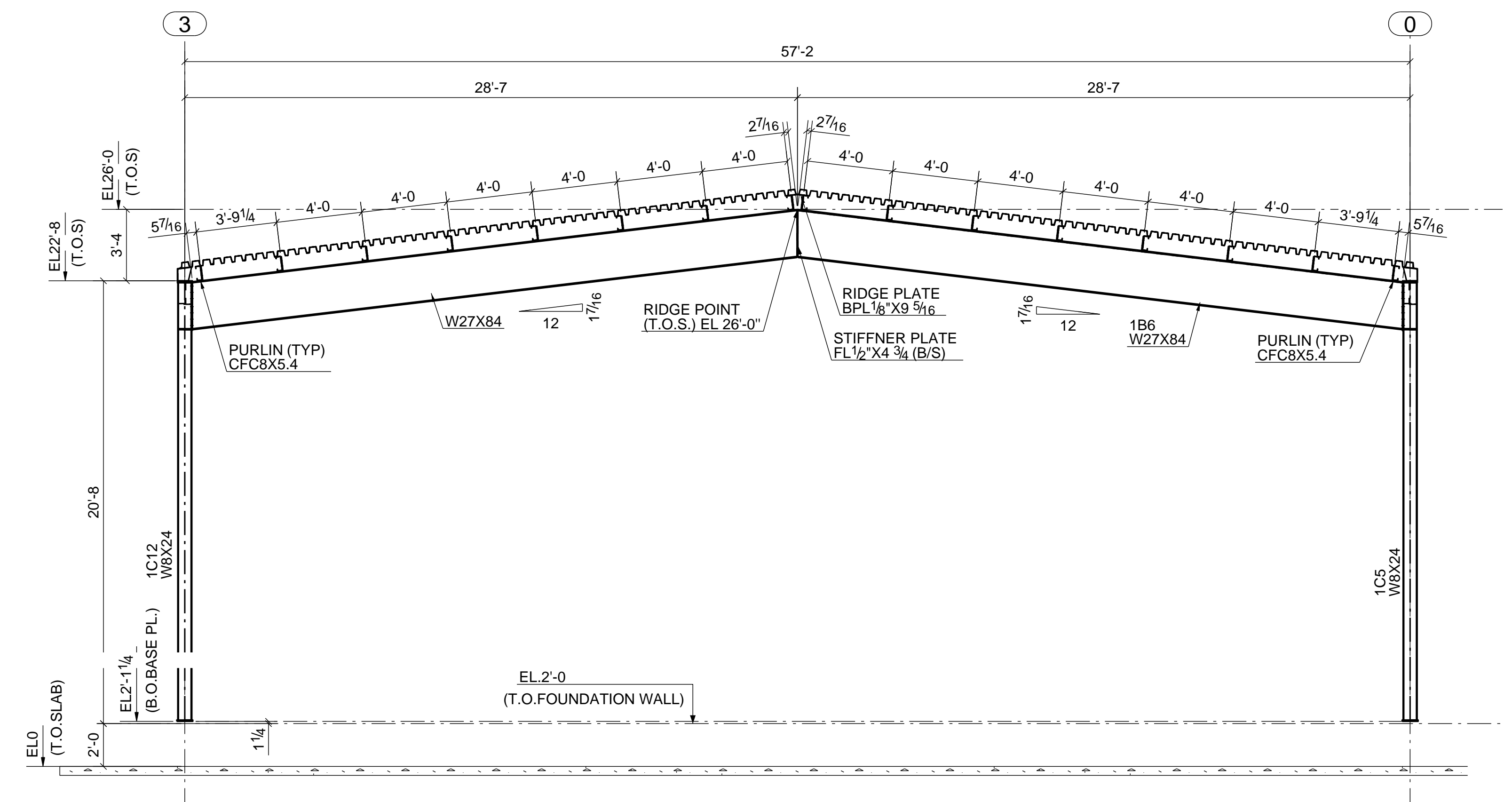

B SECTION

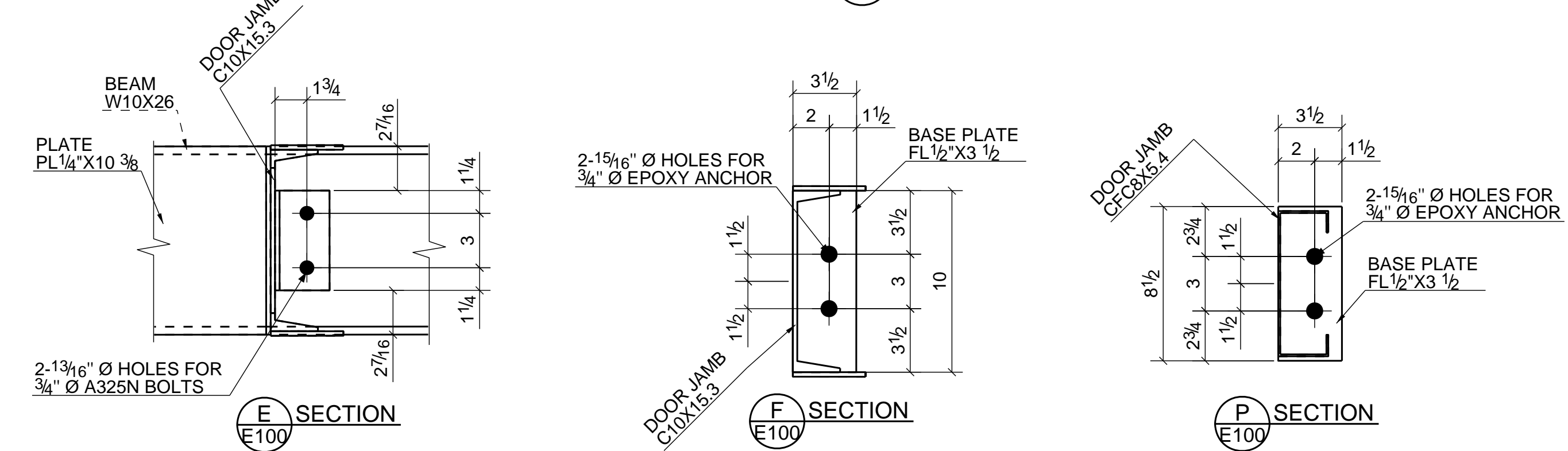

TYPICAL DOOR JAMB CONNECTION DETAILS

APPROVER'S NOTE:-
 - APPROVER TO REVIEW & VERIFY ALL THE FRAMING PLAN, ELEVATIONS AND CONNECTION DETAILS, AS SHOWN, TO MEET THE SITE REQUIREMENTS.